

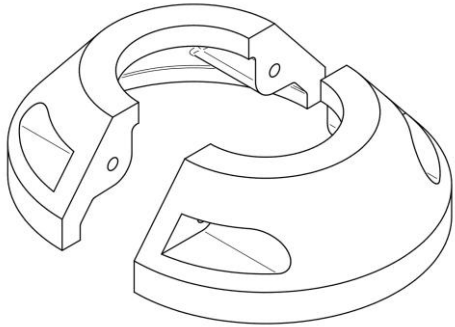

From inspiration to Castings

Printed Sand Molds for Short run parts



Part Design: Supplied by
our customer

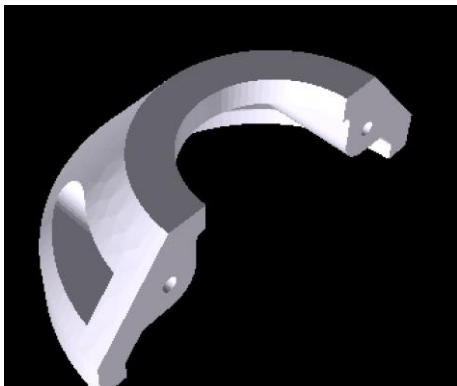

CAD Model: Supplied by
you or converted by us.
About 1 week if we convert

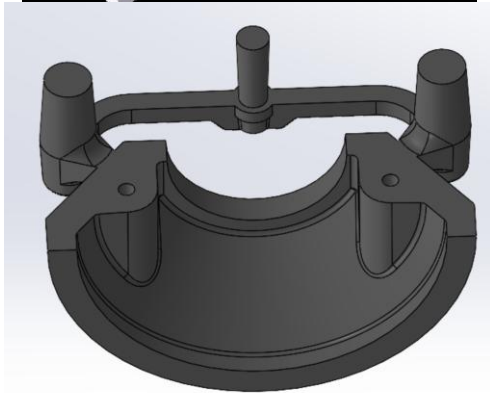

We collaborate with the
foundry to draft the part
and create a gating strategy



Our sand printing partner
prints molds and ships to
the foundry of choice.



Final castings; only 2 pieces
needed.

The OEM for these castings
was out of business and no
patterns existed.

6 Weeks, start to finish
ASTM A535 White Iron